



ACRA

The New Pinnacle of Gearless

Reaching new heights

SIGMA Reaching new heights

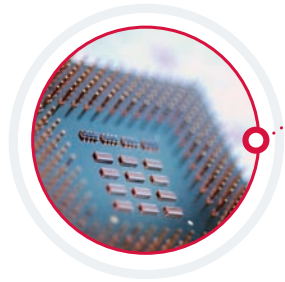

Engineered to be Safe & Reliable

Sigma products are engineered by highly qualified engineers thereby ensuring customers receive excellent products with reliable quality.



Aesthetics Design Excellence

Sigma's international design centers are staffed with professionals who continue to pursue ideal aesthetic designs to satisfy customers needs.



Global Network

Sigma has served customers in more than 60 countries over the last 40 years.



Sigma has installed over 160,000 elevators worldwide since 1978

● SIGMA SUBS ● DISTRIBUTORS

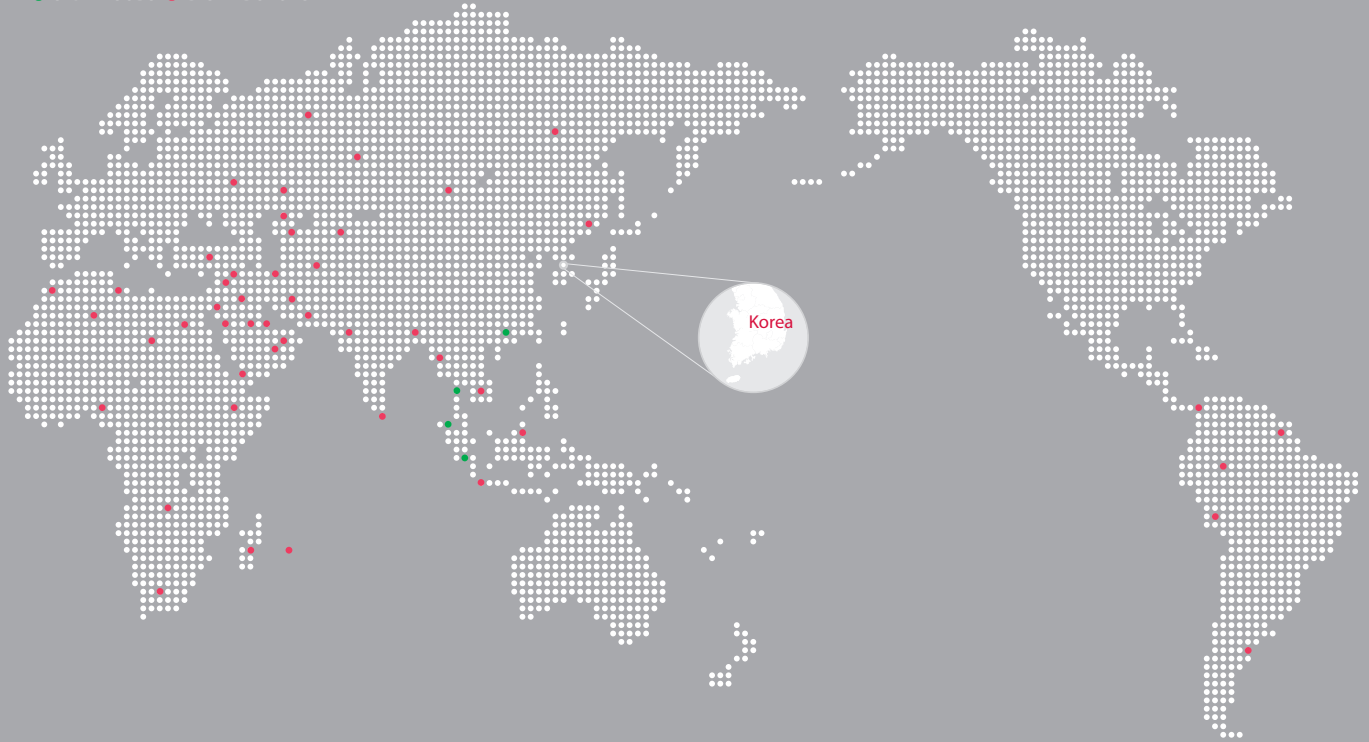

Khalid Al Attar Tower
U.A.E



Al Rames Tower
Qatar

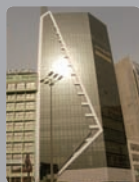

Darwaza Tower
Kuwait



Vorobiev Gory
Russia



Triumph Palace
Russia

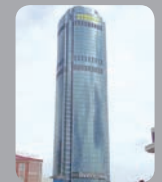

Antei
Russia



Sheraton Hotel
Puerto Rico



Baiyoke Tower
Thailand



Grand Hyatt Hotel
Indonesia



Emerald Tower
Kazakhstan



LG Beijing Tower
China



Juma Al Majid Tower
U.A.E



Armada Tower
U.A.E



Rostonskaya
Russia



Shangri La Hotel
Mongolia



Plaza La Castellana
Venezuela



Torre Global Bank
Panama



Ocean Two
Panama



Bassura Residence
Indonesia



ACRA enhancing the value of the building...

ACRA maximizing energy savings

ACRA enabling environment protections

ACRA pursuing space savings

ACRA providing ride comfort

ACRA ensuring safety & reliability

ACRA

The New Pinnacle of Gearless

Green Future in Your Life

Green Technology



Lubrication Free

The gearless machine does not need any lubrication to maintain the machine. The gearless technology helps to save about 1,400 liters of oil through the life-time of the elevator.

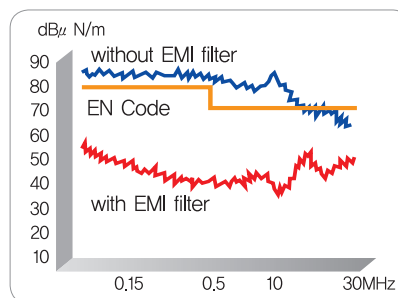

<Interference Graph>

Interference Prevention

The control panel with EMI filter prevents interference for electrical facilities. The effect of EMI filter meets or exceeds the worldwide standards on exposure to electromagnetic radiation.

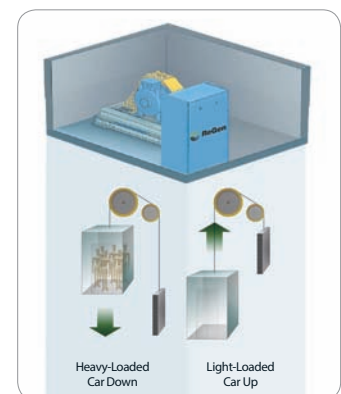

<Regeneration>

Regen System (Option)

ReGen drives significantly reduces energy demand and lowers overall building energy costs.

e*route (Option)

e*route enables passengers to reach their destinations up to 55 percent faster, reducing waiting time and avoiding congestion. Moreover, the efficiency in elevator transportation reduces the number of elevators needed, hence it leads to reducing construction cost. e*route contributes to greener environment as it reduces electrical energy consumption with its high operation efficiency.



Reliable Quality & Upgraded Safety

Reliable System

- Globally designed and manufactured
- Lower vibration and better ride quality
- UCMP & ACOP certified
(Unintended Car Movement Protection)
(Ascending Car Overspeed Protection)
- Efficient and reliable performance
- More reliable and better EMC performance
- Lower brake noise



Upgraded machine



Controller with better performance

Upgraded door operator

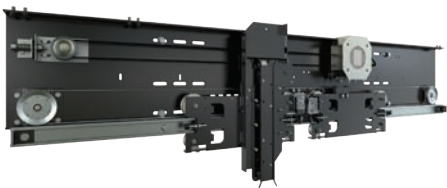

Door Impact test

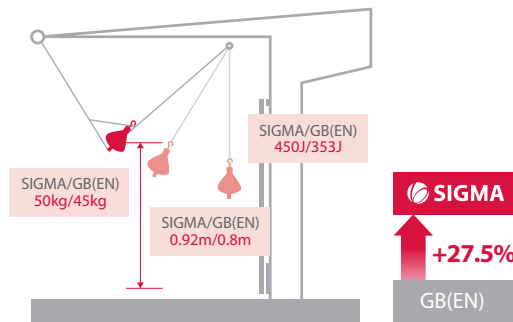

Main Safety Components

Component	SIGMA Requirements	EN81-1 Requirements
Safety Gear	25 freefall and runaway test	4 freefall test
Overspeed Governor	25 continuous tripping	20 continuous tripping
Buffer	100 strike test	6 strike test

Safety Gear



Overspeed governor



Oil buffer governor



Baiyoke Tower
Thailand





Energy Saving & Field Friendly

Energy Saving

Green

- LED light (long service life & power saving)
- Sleep mode for car lighting and fan
- Regeneration Drive (Option)

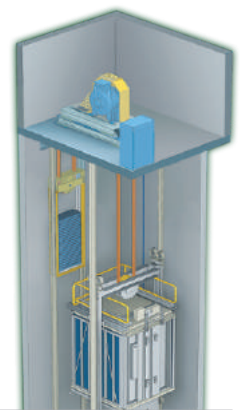

Field Friendly

Use bolt & nut to connect the car wall in hoistway

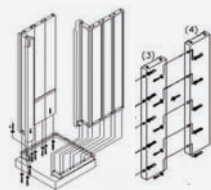

Install car panel inside car

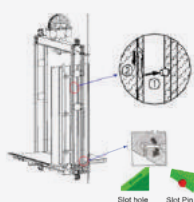

Key Benefits

High efficiency slot connection, saving labor cost

Jobsite safety improvement

No Welding
No Pollution

Welding type rail bracket

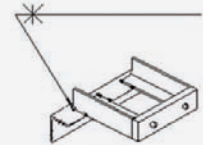

Welding-free type rail bracket

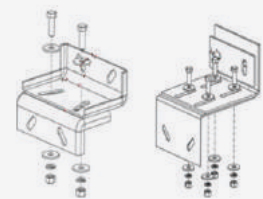

New Fixtures & Materials

New Fixtures

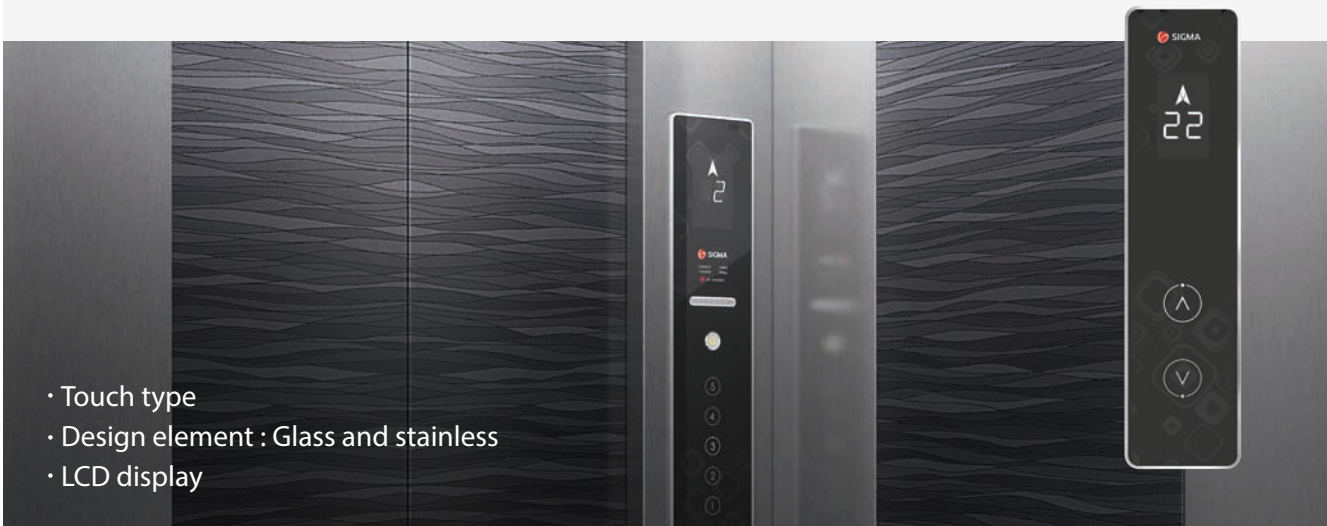
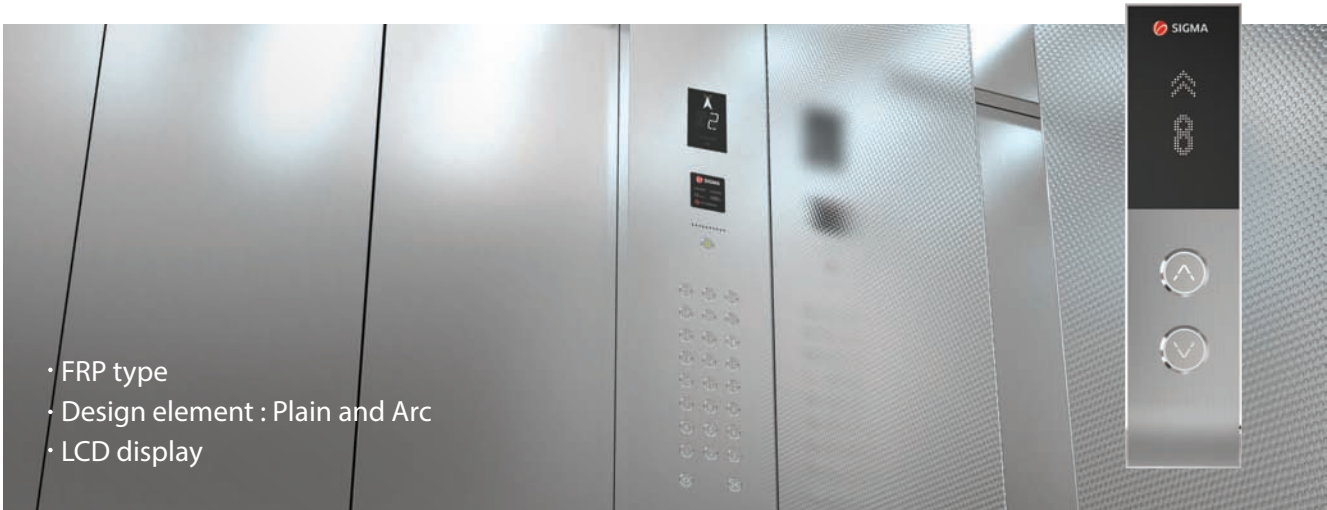

New Materials



White



Black



Bronze



Modern | Black |



| Front View |

Specification

CEILING	C-PS1
COP	COP30VG-C
CAR WALL FINISH	PCM-S01+PCM-S02
HANDRAIL	HR038POL
FLOOR	DT01



| Rear View |

 The actual product can be different (changed) depending on design
Car wall image can be different (changed) depending on capacity

Modern | Bronze |



| Front View |

Specification

CEILING	C-LA1
COP	COP30VG-C
CAR WALL FINISH	PCM-S04+PCM-S07
HANDRAIL	HR038POL
FLOOR	DT03



| Rear View |

 The actual product can be different (changed) depending on design
Car wall image can be different (changed) depending on capacity

Modern | White |

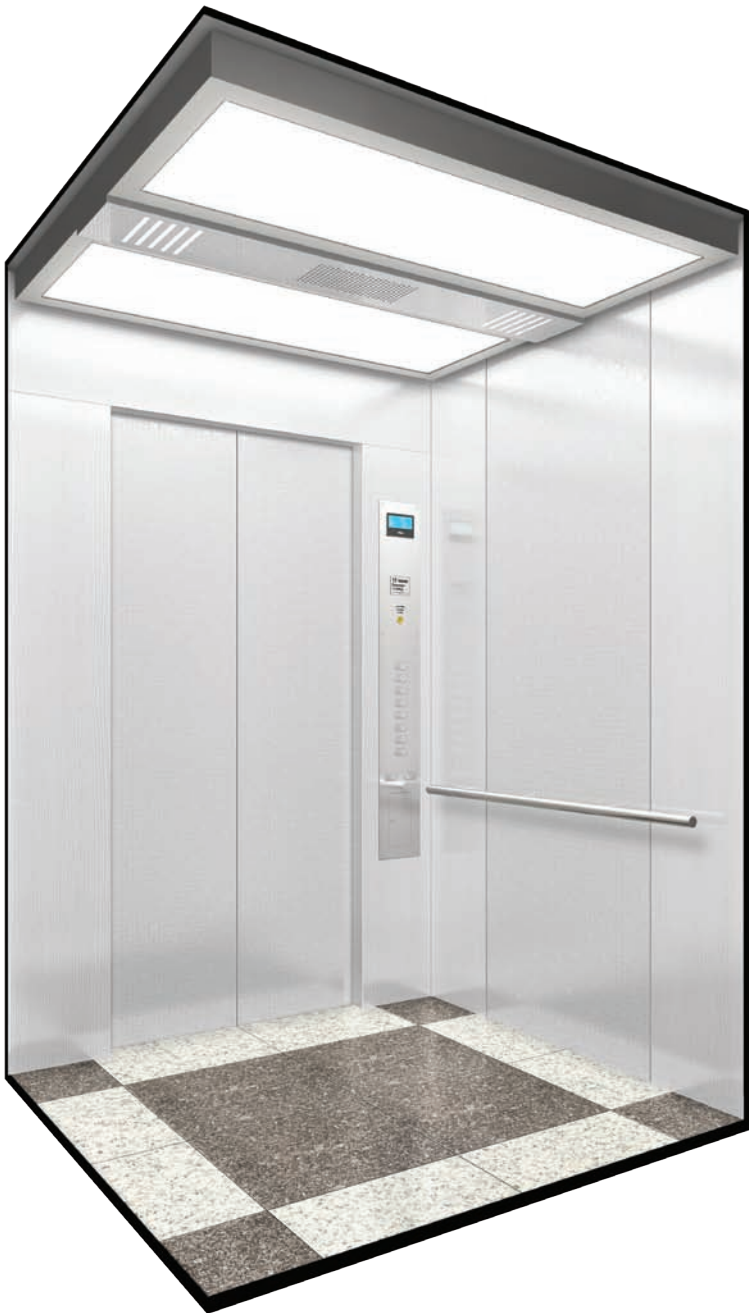

| Front View |

Specification

CEILING	CL-31
COP	CBL-85CN
CAR WALL FINISH	PCM-S05+PCM-S06
HANDRAIL	HR038POL
FLOOR	DT01



| Rear View |

 The actual product can be different (changed) depending on design
Car wall image can be different (changed) depending on capacity

Classic | Hairline |



| Front View |

Specification

CEILING	C-NL2
COP	CBX-16C
CAR WALL FINISH	Stainless Steel Hairline Etching (EW2-085)
HANDRAIL	HR038POL
FLOOR	DE313



| Rear View |

The actual product can be different (changed) depending on design
Car wall image can be different (changed) depending on capacity

Entrance



JAMB FINISH	J-301(STSMR)
DOOR FINISH	PCM-S07
HALL IND & BUTTON	VHB30BG-C

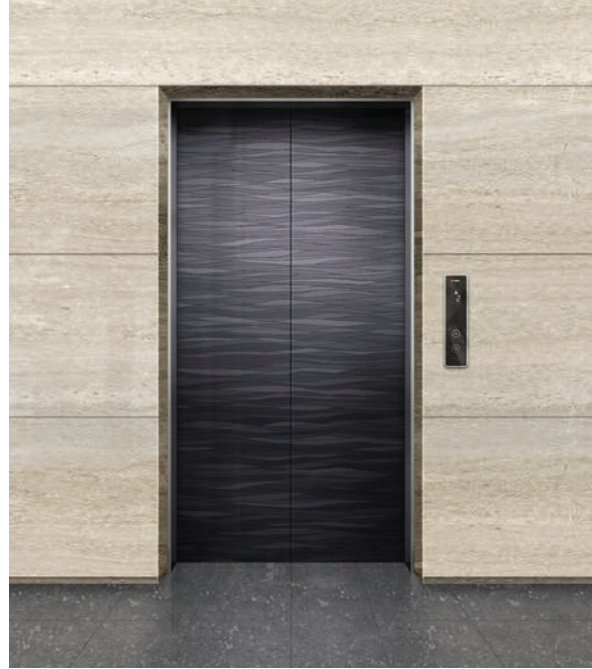

JAMB FINISH	J-101(STSMR)
DOOR FINISH	PCM-S01
HALL IND & BUTTON	VHB30BG-C



JAMB FINISH	J-311(STSMR)
DOOR FINISH	PCM-S05
HALL IND	HIL-A193
HALL BUTTON	HBM-RBBS



JAMB FINISH	J-311(STSHL)
DOOR FINISH	Stainless Steel Hairline Etching Finish(EH1-085)
HALL IND	HIX-A162
HALL BUTTON	HBM-S49

 The actual product can be different (changed) depending on design

Etching Pattern



EH3-034

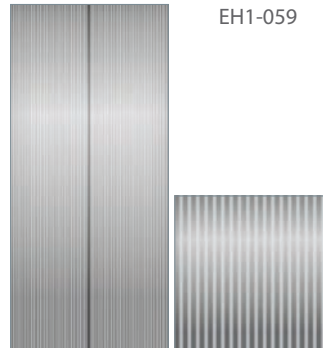

EH1-059

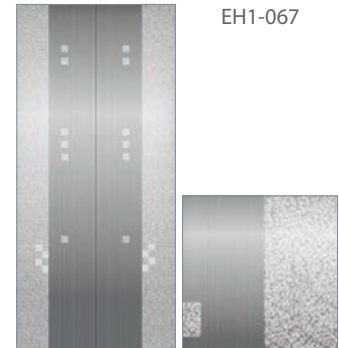

EH1-067



EH1-080

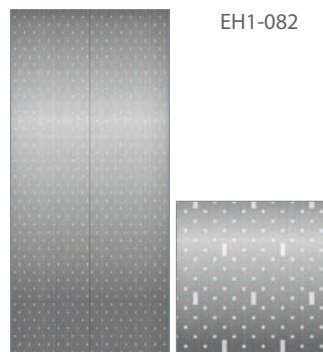

EH1-082

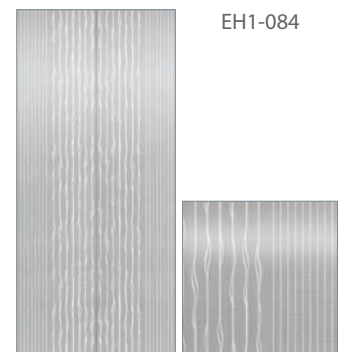

EH1-084



EH1-085

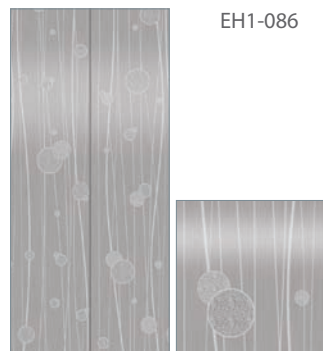

EH1-086



EH1-087

Colors

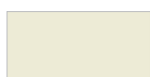

DSP002



DSP004



DSP006



DSP007



DSP008



DSP009



DSP013



DSP014



DSP015



DSP016

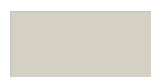

DSP017

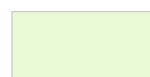

LGP925



LGP928



LGP934



LGP945



LGP946

The actual product can be different (changed) depending on design

Ceiling

Standard



C-NL2



C-RL2



C-VS2



C-NS1



C-NS3



C-ES1



C-ES2



C-ES3



C-PS1

Option



C-LA1



C-LN1



CL-31

! The actual product can be different (changed) depending on design

COP

Standard



CBX-22C



CBX-16C



CBL-85CN



CBL-82C

Option

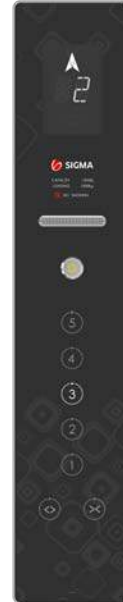

COP30VG-C



COP29FH-C



CBX-64C



CBX-D1C



CBX-D2C



COP27H-A



COP25H-A

The actual product can be different (changed) depending on design

HPI & HBT

Standard



HIX-C162



HIX-A162



HIL-A193



HIL-C193



HIX-A201



HIX-A202



HBM-R45



HBM-RA5S



HBM-R95



HBM-S49



HBM-SA9S



HBM-S99



HBM-RBBS



HBM-R65



HBM-RC5SH



HBM-RCASH

VPI

Standard



VIX-M652



VIX-M692



VIX-MA52S



VIX-MA92S



VIX-MC52SH



VIX-MCA3SH



VIL-MBB2SN



VHB30BG-C



VHB29H-C



VHB27H-AS



VHB25H-AS

! The actual product can be different (changed) depending on design

Technical Data

I Hoistway & Machine Room Plan

[Simplex]

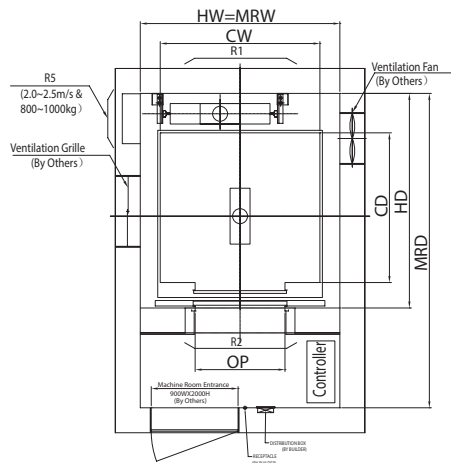

[Duplex]

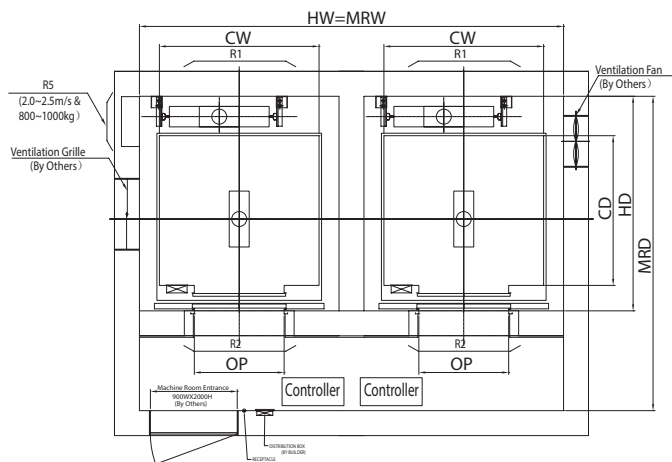

I Hoistway Section

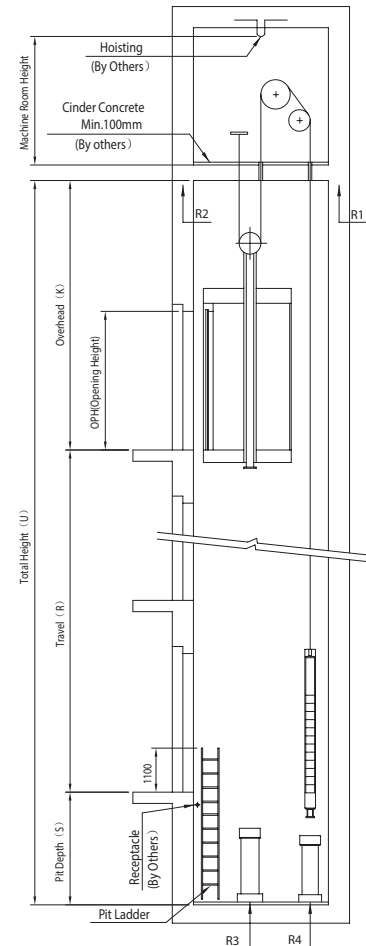

I Overhead, Pit & Machine Room Height

Speed(m/s)	Load(kg)	Travel(m)	Overhead(mm)	Pit Depth(mm)	Machine Room Height(mm)	
1.0	450~1000	TR≤100	4200	1400	2300	
	1150~1600		4300			
1.5	550~1000		4400	1450		
	1150~1600		4500	1600		
1.75	550~1000		TR≤130	5100		1900
2.0	800~1600			5300		2200
		2.5				

Technical Data

I Layout Dimensions | Speed : 1.0 m/s

[Standard]

(Unit : mm)

Speed (m/s)	Capacity		Entrance Opening (mm)	Car Size		Hoistway Size				Machine Room Size				Reaction Load (N)			
	Person	Load(kg)		CW	CD	Simplex		Duplex		Simplex		Duplex		Machine Room		Pit	
						HW	HD	HW	HD	MW	MD	MW	MD	R1	R2	R3	R4
1.0	6	450	700	1150	1030	1800	1680	3800	1680	1800	1680	3800	1680	34500	20500	67500	58700
	7	550	800	1400	1030	1800	1700	3800	1700	1800	1700	3800	1700	34500	20500	73200	62400
	8	600	800	1400	1100	1800	1750	3800	1750	1800	1750	3800	1750	34500	20500	75600	63800
	9	680	800	1400	1250	1800	1900	3800	1900	1800	1900	3800	1900	39500	23000	78600	65300
	10	800	800	1400	1350	1800	2000	3800	2000	1800	2000	3800	2000	39500	23000	84600	68900
	12	900	900	1600	1350	2000	2000	4200	2000	2000	2000	4200	2000	50000	28000	90900	73200
	13	1000	900	1600	1500	2000	2150	4200	2150	2000	2150	4200	2150	50000	28000	108300	88700
				1600	1400	2000	2050	4200	2050	2000	2050	4200	2050	50000	28000	108300	88700
	15	1150	1000	1800	1500	2350	2200	4900	2200	2350	2200	4900	2200	84600	47600	108700	86200
			1100	2000	1350	2550	2050	5300	2050	2550	2050	5300	2050				
	18	1350	1000	1800	1700	2350	2400	4900	2400	2350	2400	4900	2400	98400	53200	130000	103600
			1100	2000	1500	2550	2200	5300	2200	2550	2200	5300	2200				
21	1600	1100	2000	1750	2550	2450	5300	2450	2550	2450	5300	2450	108000	57900	143900	112500	
			2150	1600	2700	2300	5600	2300	2700	2300	5600	2300					

[EN Code]

Speed (m/s)	Capacity		Entrance Opening (mm)	Car Size		Hoistway Size				Machine Room Size				Reaction Load (N)			
	Person	Load(kg)		CW	CD	Simplex		Duplex		Simplex		Duplex		Machine Room		Pit	
						HW	HD	HW	HD	MW	MD	MW	MD	R1	R2	R3	R4
1.0	6	450	700	1150	1030	1800	1680	3800	1680	1800	1680	3800	1680	34500	20500	67500	58700
	7	550	800	1400	1030	1800	1700	3800	1700	1800	1700	3800	1700	34500	20500	73200	62400
	8	600	800	1400	1100	1800	1750	3800	1750	1800	1750	3800	1750	34500	20500	75600	63800
	9	680	800	1400	1250	1800	1900	3800	1900	1800	1900	3800	1900	39500	23000	78600	65300
	10	800	800	1400	1350	1800	2000	3800	2000	1800	2000	3800	2000	39500	23000	84600	68900
	12	900	900	1600	1350	2000	2000	4200	2000	2000	2000	4200	2000	50000	28000	90900	73200
	13	1000	900	1600	1500	2000	2150	4200	2150	2000	2150	4200	2150	50000	28000	108300	88700
				1600	1400	2000	2050	4200	2050	2000	2050	4200	2050	50000	28000	108300	88700
	15	1150	1000	1800	1500	2350	2200	4900	2200	2350	2200	4900	2200	84600	47600	108700	86200
			1100	2000	1350	2550	2050	5300	2050	2550	2050	5300	2050				
	18	1350	1000	1800	1700	2350	2400	4900	2400	2350	2400	4900	2400	98400	53200	130000	103600
			1100	2000	1500	2550	2200	5300	2200	2550	2200	5300	2200				
21	1600	1100	2000	1750	2550	2450	5300	2450	2550	2450	5300	2450	108000	57900	143900	112500	
			2150	1600	2700	2300	5600	2300	2700	2300	5600	2300					

[Malaysia]

Speed (m/s)	Capacity		Entrance Opening (mm)	Car Size		Hoistway Size				Machine Room Size				Reaction Load (N)			
	Person	Load(kg)		CW	CD	Simplex		Duplex		Simplex		Duplex		Machine Room		Pit	
						HW	HD	HW	HD	MW	MD	MW	MD	R1	R2	R3	R4
1.0	6	410	700	1150	1000	1800	1650	3800	1650	1800	1650	3800	1650	34500	20500	64900	56900
	8	545	800	1400	1030	1800	1700	3800	1700	1800	1700	3800	1700	34500	20500	72000	61400
	9	615	800	1400	1150	1800	1800	3800	1800	1800	1800	3800	1800	39500	23000	75400	63400
	10	685	800	1400	1250	1800	1900	3800	1900	1800	1900	3800	1900	39500	23000	78800	65300
	11	750	800	1400	1350	1800	2000	3800	2000	1800	2000	3800	2000	39500	23000	82300	67500
	13	885	900	1600	1350	2000	2000	4200	2000	2000	2000	4200	2000	50000	28000	90000	72700
	15	1025	900	1600	1550	2000	2200	4200	2200	2000	2200	4200	2200	50000	28000	110400	90300
	17	1160	1000	1800	1500	2350	2200	4900	2200	2350	2200	4900	2200	84600	47600	108700	86200
	20	1365	1000	1800	1750	2350	2450	4900	2450	2350	2450	4900	2450	98400	53200	130000	103600
			1100	2000	1550	2550	2250	5300	2250	2550	2250	5300	2250				
	24	1635	1100	2000	1800	2550	2500	5300	2500	2550	2500	5300	2500	108000	57900	143900	112500

Technical Data

| Layout Dimensions | Speed : 1.5m/s ~ 1.75m/s

[Standard]

(Unit : mm)

Speed (m/s)	Capacity		Entrance Opening (mm)	Car Size		Hoistway Size				Machine Room Size				Reaction Load (N)			
	Person	Load(kg)		CW	CD	Simplex		Duplex		Simplex		Duplex		Machine Room		Pit	
						HW	HD	HW	HD	MW	MD	MW	MD	R1	R2	R3	R4
1.5~1.75	7	550	800	1400	1030	1800	1700	3800	1700	1800	1700	3800	1700	34500	20500	73200	62400
	8	600	800	1400	1100	1800	1750	3800	1750	1800	1750	3800	1750	34500	20500	75600	63900
	9	680	800	1400	1250	1800	1900	3800	1900	1800	1900	3800	1900	39500	23000	78600	65300
	10	800	800	1400	1350	1800	2000	3800	2000	1800	2000	3800	2000	39500	23000	84600	68900
	12	900	900	1600	1350	2000	2000	4200	2000	2000	2000	4200	2000	50000	28000	90900	73200
	13	1000	900	1600	1500	2000	2150	4200	2150	2000	2150	4200	2150	50000	28000	108300	88700
				1600	1400	2000	2050	4200	2050	2000	2050	4200	2050	50000	28000	108300	88700
	15	1150	1000	1800	1500	2350	2200	4900	2200	2350	2200	4900	2200	84600	47600	108700	86200
			1100	2000	1350	2550	2050	5300	2050	2550	2050	5300	2050				
	18	1350	1000	1800	1700	2350	2400	4900	2400	2350	2400	4900	2400	98400	53200	130100	103600
1100			2000	1500	2550	2200	5300	2200	2550	2200	5300	2200					
21	1600	1100	2000	1750	2550	2450	5300	2450	2550	2450	5300	2450	108000	58000	143900	112500	
			2150	1600	2700	2300	5600	2300	2700	2300	5600	2300					

[EN Code]

Speed (m/s)	Capacity		Entrance Opening (mm)	Car Size		Hoistway Size				Machine Room Size				Reaction Load (N)			
	Person	Load(kg)		CW	CD	Simplex		Duplex		Simplex		Duplex		Machine Room		Pit	
						HW	HD	HW	HD	MW	MD	MW	MD	R1	R2	R3	R4
1.5~1.75	7	550	800	1400	1030	1800	1700	3800	1700	1800	1700	3800	1700	34500	20500	73200	62400
	8	600	800	1400	1100	1800	1750	3800	1750	1800	1750	3800	1750	34500	20500	75600	63900
	9	680	800	1400	1250	1800	1900	3800	1900	1800	1900	3800	1900	39500	23000	78600	65300
	10	800	800	1400	1350	1800	2000	3800	2000	1800	2000	3800	2000	39500	23000	84600	68900
	12	900	900	1600	1350	2000	2000	4200	2000	2000	2000	4200	2000	50000	28000	90900	73200
	13	1000	900	1600	1500	2000	2150	4200	2150	2000	2150	4200	2150	50000	28000	108300	88700
				1600	1400	2000	2050	4200	2050	2000	2050	4200	2050	50000	28000	108300	88700
	15	1150	1000	1800	1500	2350	2200	4900	2200	2350	2200	4900	2200	84600	47600	108700	86200
			1100	2000	1350	2550	2050	5300	2050	2550	2050	5300	2050				
	18	1350	1000	1800	1700	2350	2400	4900	2400	2350	2400	4900	2400	98400	53200	130100	103600
1100			2000	1500	2550	2200	5300	2200	2550	2200	5300	2200					
21	1600	1100	2000	1750	2550	2450	5300	2450	2550	2450	5300	2450	108000	58000	143900	112500	
			2150	1600	2700	2300	5600	2300	2700	2300	5600	2300					

[Malaysia]

Speed (m/s)	Capacity		Entrance Opening (mm)	Car Size		Hoistway Size				Machine Room Size				Reaction Load (N)			
	Person	Load(kg)		CW	CD	Simplex		Duplex		Simplex		Duplex		Machine Room		Pit	
						HW	HD	HW	HD	MW	MD	MW	MD	R1	R2	R3	R4
1.5~1.75	8	545	800	1400	1030	1800	1700	3800	1700	1800	1700	3800	1700	34500	20500	72000	61400
	9	615	800	1400	1150	1800	1800	3800	1800	1800	1800	3800	1800	39500	23000	75400	63400
	10	685	800	1400	1250	1800	1900	3800	1900	1800	1900	3800	1900	39500	23000	78800	65300
	11	750	800	1400	1350	1800	2000	3800	2000	1800	2000	3800	2000	39500	23000	82300	67500
	13	885	900	1600	1350	2000	2000	4200	2000	2000	2000	4200	2000	50000	28000	90000	72700
	15	1025	900	1600	1550	2000	2200	4200	2200	2000	2200	4200	2200	50000	28000	110400	90300
	17	1160	1000	1800	1500	2350	2200	4900	2200	2350	2200	4900	2200	84600	47600	108700	86200
	20	1365	1000	1800	1750	2350	2450	4900	2450	2350	2450	4900	2450	98400	53200	130100	103600
			1100	2000	1550	2550	2250	5300	2250	2550	2250	5300	2250				
	24	1635	1100	2000	1800	2550	2500	5300	2500	2550	2500	5300	2500	108000	57900	143900	112500

Technical Data

| Layout Dimensions | Speed : 2.0m/s ~ 2.5m/s

[Standard]

(Unit : mm)

Speed (m/s)	Capacity		Entrance Opening (mm)	Car Size		Hoistway Size				Machine Room Size				Reaction Load (N)				
	Person	Load(kg)		CW	CD	Simplex		Duplex		Simplex		Duplex		Machine Room			Pit	
						HW	HD	HW	HD	MW	MD	MW	MD	R1	R2	R5	R3	R4
2.0~2.5	10	800	800	1400	1350	1950	2050	4100	2050	1950	2050	4100	2050	45000	27500	6000	102100	86400
	12	900	900	1600	1350	2150	2050	4500	2050	2150	2050	4500	2050	54500	31500	7000	109400	91700
	13	1000	900	1600	1500	2150	2200	4500	2200	2150	2200	4500	2200	54500	31500	7000	114500	94900
				1600	1400	2150	2100	4500	2100	2150	2100	4500	2100	54500	31500	7000	114500	94900
	15	1150	1000	1800	1500	2350	2200	4900	2200	2350	2200	4900	2200	123000	82500	-	169200	129700
			1100	2000	1350	2550	2050	5300	2050	2550	2050	5300	2050	131000	88500	-	180400	135500
	18	1350	1000	1800	1700	2350	2400	4900	2400	2350	2400	4900	2400	131000	88500	-	180400	135500
			1100	2000	1500	2550	2200	5300	2200	2550	2200	5300	2200	139000	93500	-	196000	144200
	21	1600	1100	2000	1750	2550	2450	5300	2450	2550	2450	5300	2450	139000	93500	-	196000	144200
				2150	1600	2700	2300	5600	2300	2700	2300	5600	2300	139000	93500	-	196000	144200

[EN Code]

Speed (m/s)	Capacity		Entrance Opening (mm)	Car Size		Hoistway Size				Machine Room Size				Reaction Load (N)				
	Person	Load(kg)		CW	CD	Simplex		Duplex		Simplex		Duplex		Machine Room			Pit	
						HW	HD	HW	HD	MW	MD	MW	MD	R1	R2	R5	R3	R4
2.0~2.5	10	800	800	1400	1350	1950	2050	4100	2050	1950	2050	4100	2050	45000	27500	6000	102100	86400
	12	900	900	1600	1350	2150	2050	4500	2050	2150	2050	4500	2050	54500	31500	7000	109400	91700
	13	1000	900	1600	1500	2150	2200	4500	2200	2150	2200	4500	2200	54500	31500	7000	114500	94900
				1600	1400	2150	2100	4500	2100	2150	2100	4500	2100	54500	31500	7000	114500	94900
	15	1150	1000	1800	1500	2350	2200	4900	2200	2350	2200	4900	2200	123000	82500	-	169200	129700
			1100	2000	1350	2550	2050	5300	2050	2550	2050	5300	2050	131000	88500	-	180400	135500
	18	1350	1000	1800	1700	2350	2400	4900	2400	2350	2400	4900	2400	131000	88500	-	180400	135500
			1100	2000	1500	2550	2200	5300	2200	2550	2200	5300	2200	139000	93500	-	196000	144200
	21	1600	1100	2000	1750	2550	2450	5300	2450	2550	2450	5300	2450	139000	93500	-	196000	144200
				2150	1600	2700	2300	5600	2300	2700	2300	5600	2300	139000	93500	-	196000	144200

[Malaysia]

Speed (m/s)	Capacity		Entrance Opening (mm)	Car Size		Hoistway Size				Machine Room Size				Reaction Load (N)				
	Person	Load(kg)		CW	CD	Simplex		Duplex		Simplex		Duplex		Machine Room			Pit	
						HW	HD	HW	HD	MW	MD	MW	MD	R1	R2	R5	R3	R4
2.0~2.5	11	750	800	1400	1350	1950	2050	4100	2050	1950	2050	4100	2050	45000	27500	6000	100000	85300
	13	885	900	1600	1350	2150	2050	4500	2050	2150	2050	4500	2050	54500	31500	7000	108800	91500
	15	1025	900	1600	1550	2150	2250	4500	2250	2150	2250	4500	2250	54500	31500	7000	116600	96500
	17	1160	1000	1800	1500	2350	2200	4900	2200	2350	2200	4900	2200	123000	82500	-	169200	129700
	20	1365	1000	1800	1750	2350	2450	4900	2450	2350	2450	4900	2450	131000	88500	-	180400	135500
			1100	2000	1550	2550	2250	5300	2250	2550	2250	5300	2250	139000	93500	-	196000	144200
	24	1635	1100	2000	1800	2550	2500	5300	2500	2550	2500	5300	2500	139000	93500	-	196000	144200

Technical Data

| Power Supply Plan | Speed : 1.0~2.5 m/s

(380V)

Speed (m/s)	Capacity		Motor Capacity (kW)	MCCB Capacity of Building (A)		Power Supply Capacity (kVA)		Lead-in Wire Size (mm ²)		Earth Wire Size (mm ²)		Heat Dissipation (J/H)	Starting Power (KVA/set)
	Person	Load(kg)		Simplex	Duplex	Simplex	Duplex	Simplex	Duplex	Simplex	Duplex		
1.0	6	450	3.9	25	25	5.3	9.7	6	6	6	6	675	7.8
	7	550	3.9	25	25	5.9	10.8	6	6	6	6	825	7.8
	8	600	3.9	25	25	6.3	11.5	6	6	6	6	900	7.8
	9	680	4.9	25	32	7.3	13.4	6	6	6	6	1020	9.8
	10	800	4.9	25	40	8.9	16.2	6	6	6	6	1200	9.8
	12	900	6.2	25	40	8.9	16.2	6	6	6	6	1350	12.4
	13	1000	6.2	25	50	9.8	17.8	6	10	6	6	1500	12.4
	15	1150	8.2	32	50	11.1	20.3	6	10	6	6	1725	16.4
	18	1350	8.8	32	75	13.0	26.0	10	16	6	6	2025	17.6
21	1600	10.5	40	75	15.5	31.0	10	16	6	10	2400	21.0	
1.5	6	450	5.8	25	32	8.7	15.8	6	10	6	6	1013	11.6
	7	550	5.8	25	32	9.7	17.7	6	10	6	6	1238	11.6
	8	600	5.8	25	40	10.4	18.9	6	10	6	6	1350	11.6
	9	680	7.4	25	40	11.5	20.9	6	10	6	6	1530	14.8
	10	800	7.4	32	50	13.5	24.6	10	10	6	6	1800	14.8
	12	900	9.2	32	50	13.5	24.6	10	16	6	6	2025	18.4
	13	1000	9.2	32	60	14.9	27.1	10	16	6	6	2250	18.4
	15	1150	12.3	40	75	18.2	33.1	16	16	6	6	2588	24.6
	18	1350	13.2	50	100	21.2	42.4	16	25	6	10	3038	26.4
21	1600	15.7	60	120	25.3	50.5	16	35	6	10	3600	31.4	
1.75	6	450	6.8	25	32	10.5	19.1	6	10	6	6	1181	13.6
	7	550	6.8	25	40	11.7	21.4	6	10	6	6	1444	13.6
	8	600	6.8	25	40	12.5	22.8	6	10	6	6	1575	13.6
	9	680	8.6	25	50	13.9	25.2	6	10	6	6	1785	17.2
	10	800	8.6	32	60	16.4	29.8	10	10	6	6	2100	17.2
	12	900	10.8	32	60	16.4	29.8	10	16	6	6	2363	21.6
	13	1000	10.8	40	75	18.0	32.7	10	16	6	6	2625	21.6
	15	1150	14.3	50	100	21.0	38.2	16	25	6	10	3019	28.6
	18	1350	15.4	50	100	24.4	48.9	16	25	6	10	3544	30.8
21	1600	18.3	60	120	29.1	58.3	16	35	6	10	4200	36.6	
2.0	10	800	10.3	40	60	13.1	23.8	10	25	6	10	2250	20.6
	12	900	13.3	40	75	15.4	28.0	16	35	6	10	2700	26.6
	13	1000	13.3	50	100	17.1	31.1	16	50	6	16	3000	26.6
	15	1150	16.3	50	100	19.9	36.1	16	50	6	16	3450	32.6
	18	1350	17.6	60	100	21.6	39.3	16	50	6	16	4050	35.2
	21	1600	20.9	75	125	26.2	47.6	16	70	10	25	4800	41.8
2.5	10	800	13.1	50	75	16.2	29.5	16	35	6	10	2873	26.2
	12	900	16.8	50	100	19.0	34.5	16	50	6	16	3375	33.6
	13	1000	16.8	60	100	21.1	38.3	16	50	6	16	3750	33.6
	15	1150	20.4	60	125	23.9	43.6	16	70	6	25	4313	40.8
	18	1350	22.1	75	125	26.2	47.8	25	70	10	25	5063	44.2
21	1600	26.1	100	150	31.4	57.2	25	70	10	25	6000	52.2	

Technical Data Hospital

I Hoistway & Machine Room Plan

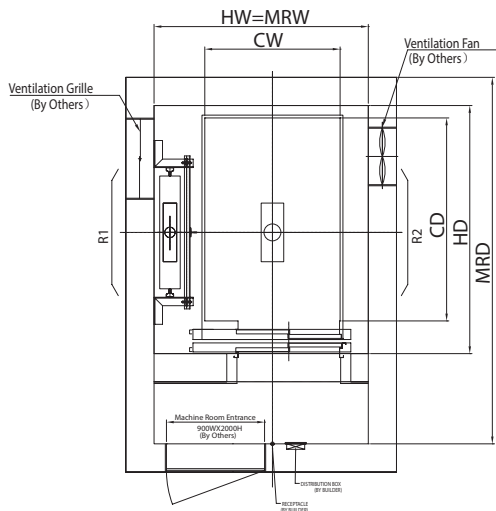

I Hoistway Section

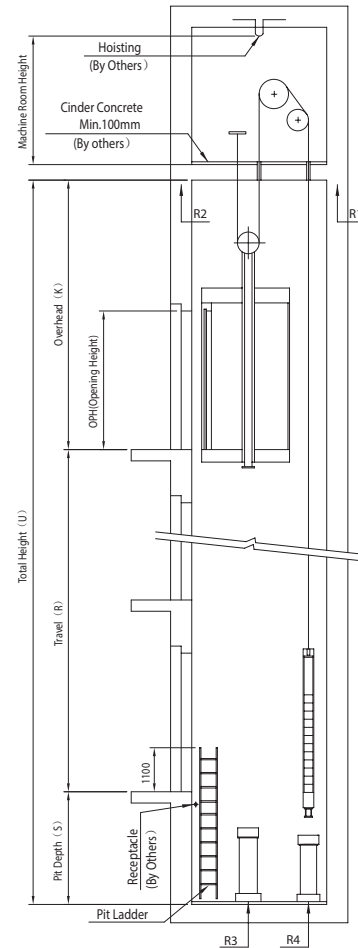

I Layout Dimensions | Speed : 1.0m/s~2.5m/s

[Standard]

(Unit : mm)

Speed (m/s)	Capacity		Entrance Opening (mm)	Car Size		Hoistway Size				Machine Room Size				Reaction Load (N)			
	Person	Load(kg)		CW	CD	Simplex		Duplex		Simplex		Duplex		Machine Room		Pit	
						HW	HD	HW	HD	MW	MD	MW	MD	R1	R2	R3	R4
1.0	18	1350	1000	1300	2300	2250	2750	4700	2750	2250	2750	4700	2750	131000	88500	180400	135500
~ 2.5	21	1600	1100	1500	2300	2400	2750	5000	2750	2400	2750	5000	2750	139000	93500	198700	144200

Technical Data

Narrow Jamb without Transom Panel

Section B-B

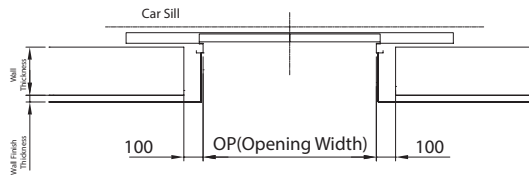

Section A-A

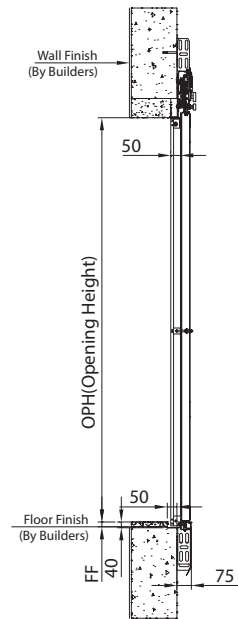

Front View of Entrance

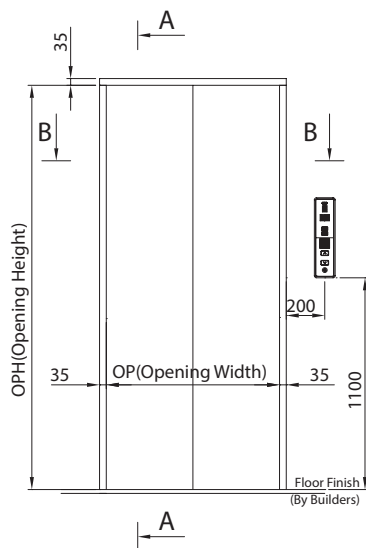

Building Structure Plan (Normal Button)

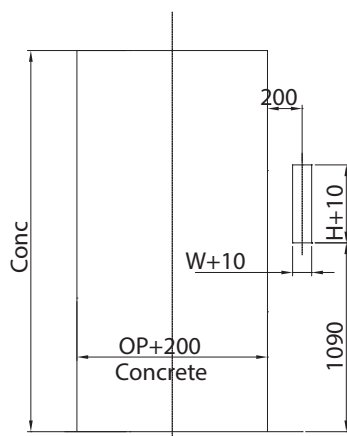

Building Structure Plan (Slim Type Button)

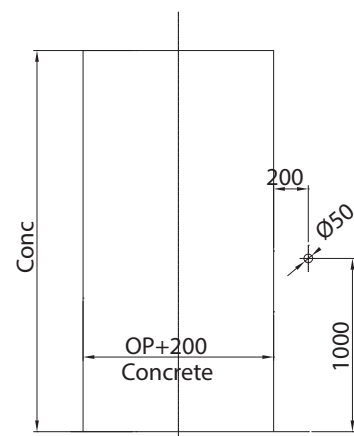

Note 1. «H» dimension in building structure plan depends upon the type of hall indicator selected.
2. Unit : mm

Technical Data

S-Type Wide Jamb with Transom Panel

| Section B-B

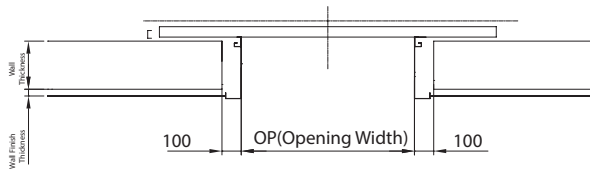

| Section A-A

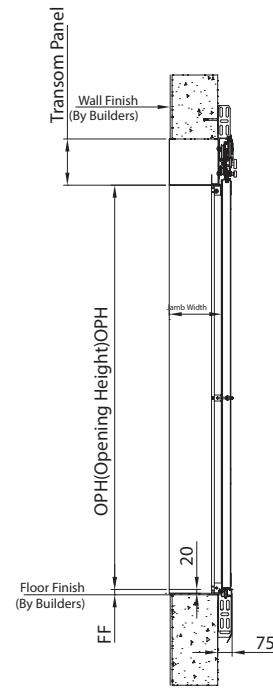

| Front View of Entrance

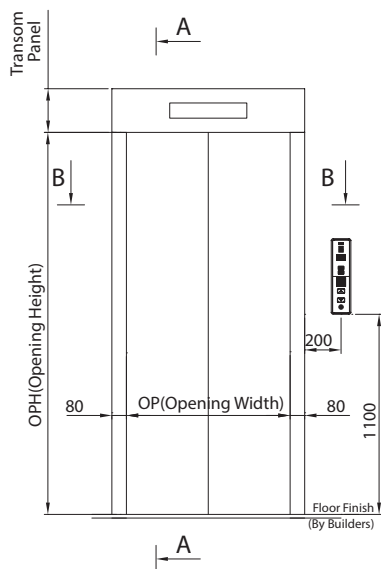

| Building Structure Plan (Normal Button)

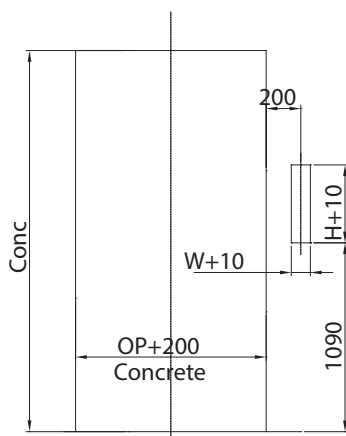

| Building Structure Plan (Slim Type Button)

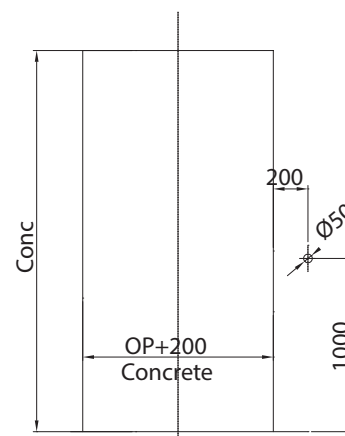

Note 1. «H» dimension in building structure plan depends upon the type of hall indicator selected.
2. Unit : mm

Technical Data

T-Type Jamb with Transom Panel

Section B-B

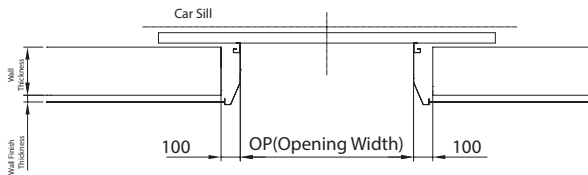

Section A-A

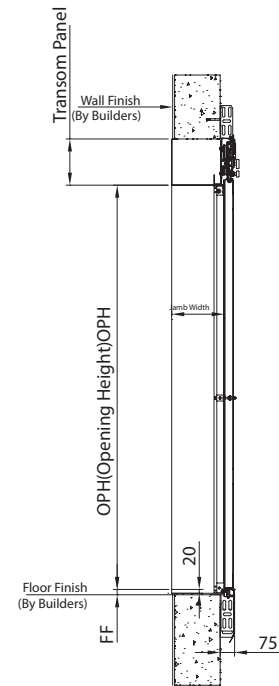

Front View of Entrance

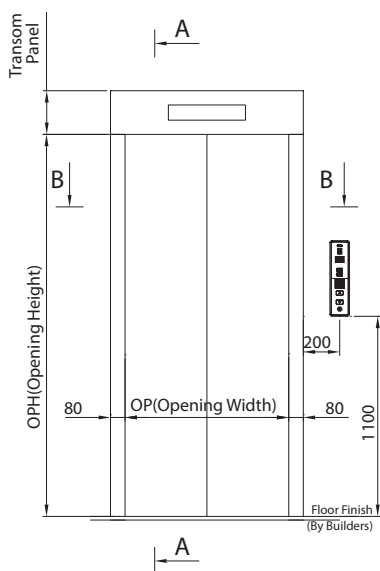

Building Structure Plan (Normal Button)

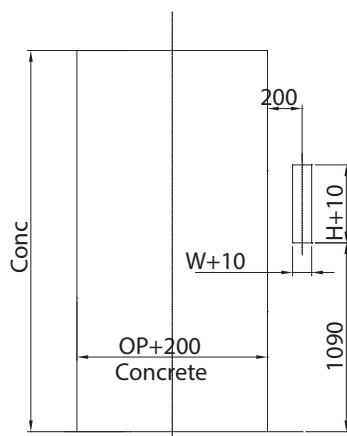

Building Structure Plan (Slim Type Button)

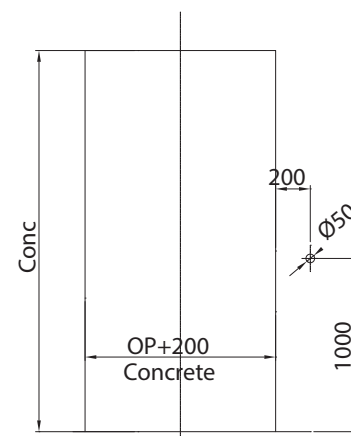

Note 1. «H» dimension in building structure plan depends upon the type of hall indicator selected.
2. Unit : mm

Technical Data

Technical Features

I Operation Functions

● Standard ○ Option

Features	Description	
Safety Drive Operation	During normal operation, a malfunction is occurred suddenly but it's not serious, in this case, if the car is not in a door zone, then the car starts to run to the nearest floor, the car remains stop with door fully open and "Out of service" lamp.	●
Detection of Jammed Hall Button and Exclusion From Operation Service	If a hall button is jammed mechanically, the hall call will be automatically bypassed after being served once, until the problem is resolved.	●
Attendant Operation	The operating mode of an elevator can be changed from the normal automatic operation to the attendant service by an attendant switch.	●
Independent Operation	Key switch in the car operating panel will cancel any existing hall calls and hold the door open at the landing position. During independent operation, the car will respond only to respond car calls.	●
Anti-nuisance Operation	In case of substantial difference between the number of calls registered on the car operating panel and actual load in the elevator, the elevator prevents unnecessary operation by canceling all registered calls when it arrives at the nearest floor.	●
Car Call Cancellation	Allows cancellation of an incorrectly registered car call. If you push a wrong floor button in the car, you can cancel it by pressing the same button one more time.	●
Nearest Stop	When the car stops between floors due to mechanical malfunction. It will move to the nearest floor for the emergency escape.	●
Automatic Door Open & Close Time Adjustment	Door open and close are automatically adjusted depending on whether the car is a hall call or a car call to increase the operating efficiency.	●
Car Door Safety Edge	Extending the full height of the car door, this device enables the doors to return to the fully open position, should the door encounter a person or obstacle while closing.	●
Automatic Car Light & Fan Turn-off	Car illumination and fan are turned off automatically in case there is no hall call or car call to save energy.	●
By Pass Operation (80%)	If the actual load comes to more than 80% of the allowable maximum load, the elevator will not react to the calling signals from other passing floors.	●
Over Load (110% of rated load) Holding Stop	When the load of passengers exceeds the maximum capacity, a buzzer sounds and the elevator remains stopped at that floor. When the passengers get off, the buzzer will stop. Consequently elevator doors will close and operation continues.	●
Car Position Display	Car position display in car or hall, operated by car indicator or hall indicator.	●
Over Speed Governor	Located at the top of the hoist way, engages the governor rope, causing activation of the elevator safety device, should the elevator car accelerate beyond the predetermined maximum speed in the "up and down" direction.	●
Emergency Lighting Feature	In case of power failure, the emergency light will turn on and maintain a period of time.	●
Changeable Reference Floor	The reference floor can be changed by the customer.	●
Slow Running when Checking and Repairing	When checking and repairing, the elevator will operate slowly to ensure the worker' safety.	●

● Standard ○ Option

Features	Description	
Terminal Limit Switches	Prevent the elevator from traveling beyond a terminal landing, in dependent of the functioning of the operating device.	●
Interphone	Provide emergency communication between passengers in the car, the machine room or building personnel in a security or maintenance room.	●
Car Chime	Arrival signal.	●
Hall Button Jam	When hall button continues to be active long time, a car could be ignore the hall call.	●
ERO&MSK Operation	ERO: Refer to GB7588-2003 14.2.1.4, MSK for SIGMA.	●
Emergency Firemen Service	In case of fire, firemen can use the elevator which is stopped at the specified floor in order to support firemen for fire-fighting.	○
Emergency Fire Return Operation	In case of fire, every car should be returned to the specified floor in order to evacuate passengers to safety.	○
Automatic Rescue Device(ALP)	In case of power failure, when the building has no emergency power supply, the elevator is sent to the nearest floor by DC power of battery to prevent passengers from being trapped in the car.	○
Door Nudging	When the doors remain open for more than the fixed door open time (approx. 20 seconds), this feature closes the doors at reduced closing speed with buzzer sounding.	○
Supervisory Interface and EMS	CRT interface and DOS100 interface is applicable to SI210 controller only.(need I/F board)	○
Earthquake	The earthquake sensor detects whether the earthquakes occur or not. When earthquakes occur, the device forces the elevator to stop at the nearest floor with door fully open, and the elevator can't operate any more.	○
Cancel Hall Chime	To cancel hall Chime in night, in order to keep quiet for people.	○
Voice Synthesizer	MICOM to the elevators on the synthesized speech The ability to automatically broadcast the status information.	○
Hall Call Canceling	This feature is available to simplex operation only. - Allows cancellation of an incorrectly registered hall call. - At landing floor, this operation is not available for door re-opening.	○
Night Noise Restriction	A timer or RTC (Real Time Clock) activates this feature. When RTC reaches designated time, chime and/or gong is deactivated.	○
Auto Changed Basement	The car serves the basement. This may be one or more basement floors. A timer or RTC (Real Time Clock) activates this feature. When RTC reaches designated time, basement floor can be changed automatically.	○
Canceling Group Operation	A car can be separated from two-car group operation by a switch or EMS command and be operated standalone.	○
Wait with Opened Door	A car Wait with Opened Door at basement floors.	○
Through Type	Opened front door and rear Door.	○
Generator Operation	When power off, receive power from generator, and operate according to procedure of Generator.	○
Re-leveling	Adjust leveling between landing sill and Car sill.	○



ISO 9001
Certificate



ISO 14001
Certificate



Sigma head office:
8F Two IFC
10 Gukjegeumyung-ro, Youngdeungpo-gu
Seoul 150-945, Korea

Distributor's office:



SIGMA

Reaching new heights
www.sigmaelevator.com